

Creating the Future

**SATAKE**

Simple Operation / Stable Performance

# GRAIN COLOR SORTER

**GS17641AIS**

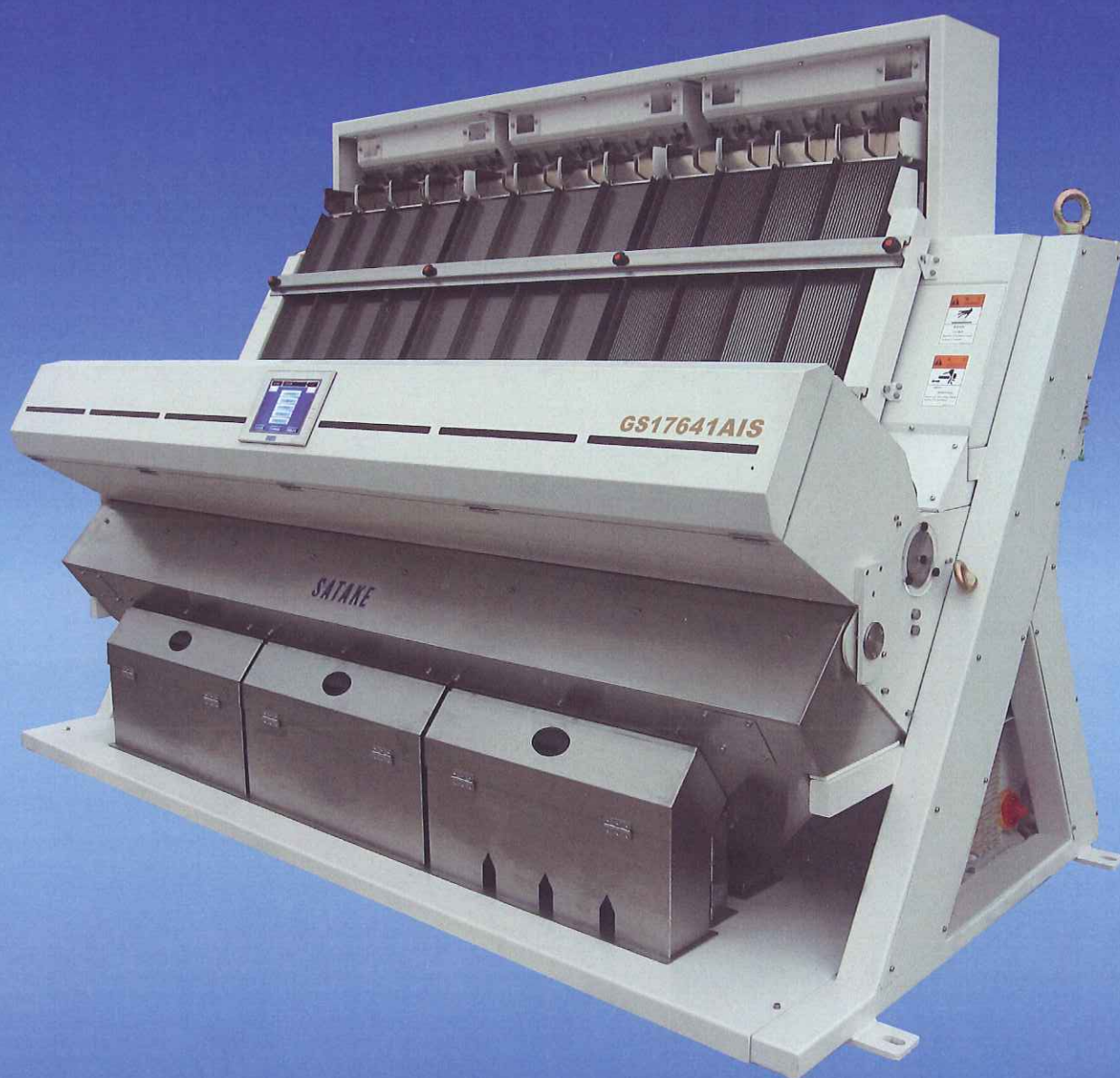

**SATAKE CORPORATION**

### 1) High Capacity, Color Touch Panel

The machine has 12 1764mm chutes which can process up to 20 tons of material per hour. A color touch panel provides easy operation and maintenance.

### 2) Stable

This model boasts an automatic calibration feature. When the fluorescent lamps become dark or the material condition changes, the CPU automatically recalibrates the signal readouts. Precise sorting performance is maintained for longer periods without the need for intensive adjustment by an operator.

### 3) User Friendly

The new software comes pre programmed. Operation has been made much simpler, eliminating uneven sorting performance due to human error. The Optical Sorter achieves remarkable performance on the parboiled rice sorting, as the new software is equipped with a feature to detect pale yellow.

### 4) Durable

The front and rear optical sections and the power unit are individually modulated, isolated and sealed. They are impervious to dust and bran, and dissipate waste heat to other parts of the equipment.

### 5) Flexible

The allocation of chutes for primary and secondary sorting is selectable. When defect contamination is high and a lot of primary reject is expected, the chute proportion can be changed on site in less than 30 minutes.

### 6) Easy Maintained

The modulated front optical section can be withdrawn for easy maintenance and quick replacement of fluorescent lamps.

## GRAIN COLOR SORTER

### Specifications

Model		GS17641AIS
Power Requirement	Max	4.3kW
	Rated	3.8kW
Air Pressure		0.5MPa
Air Consumption		1600 - 3500 NI
Maximum Throughput (Milled rice with less than 1%contamination)	Short Grain	18 - 20 t/H
	Long Grain	14 - 16 t/H
Channel Proportion	Standard	210 : 42
	Optional 1 (Primary : Secondary)	189 : 63
	Optional 2 (Primary : Secondary : Tertiary)	168 : 42 : 42
Number of CCD Camera		24 units

### Dimensions

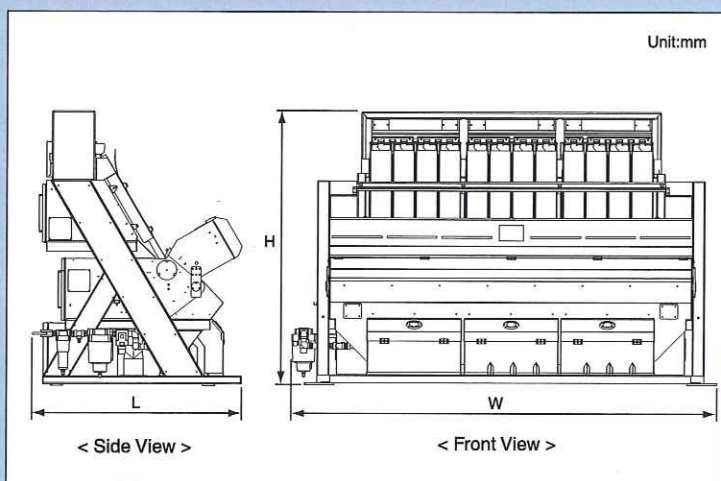

Model	W(mm)	L(mm)	H(mm)	Net Weight (kg)
GS17641AIS	2,854	1,333	1,822	1,250

All Satake products are the subject of continuous development and, as a result, their specification may change and differ in detail from those shown.

## SATAKE CORPORATION

**Head Office**  
2-30 Saijo Nishihonmachi,  
Higashi-Hiroshima-shi,  
Hiroshima-ken, 739-8602, Japan  
Tel : +81-82-420-8560/8539  
Fax : +81-82-420-0865  
e-mail : international@satake-japan.co.jp  
URL : www.satake-japan.co.jp

**SATAKE USA INC.**  
10905 Cash Road,  
Stafford, Texas, 77477, U.S.A.  
Tel : +1-281-276-3600  
Fax : +1-281-494-1460  
e-mail : rice@satake-usa.com  
URL : www.satake-usa.com

**SATAKE (CANADA) INC.**  
5100 Falingbrook Drive,  
Mississauga, Ontario, L5V 1S7,  
Canada  
Tel : +1-905-858-0791  
Fax : +1-905-858-0957  
e-mail : sales@satake-canada.com

**SATAKE AMERICA LATINA LTDA.**  
Rua Xavantes, 155-Pav. 20,  
Bairro Atiradores, CEP  
89203-210, Joinville, Santa  
Catarina, Brazil  
Tel : +55-47-3461-1313  
Fax : +55-47-3461-1300  
e-mail : ricardo@satake.com.br

**SATAKE EUROPE LTD.**  
P.O. Box 53, Horsfield Way,  
Bredbury Industrial Park, Bredbury,  
Stockport, Cheshire, SK6 2FG, U.K.  
Tel : +44-161-406-3800  
Fax : +44-161-406-3801  
e-mail : sales@satake-europe.com  
URL : www.satake-europe.com

**SATAKE INDIA ENGINEERING PVT. LTD.**  
4th Floor, Tower-1, HB Twin Towers,  
A2, 3, 4, Netaji Subhash Place,  
Wazirpur District Centre, New  
Delhi, 110034, India  
Tel : +91-11-4706-2626  
Fax : +91-11-4706-2624  
e-mail : satake@del2.vsnl.net.in

**SATAKE (THAILAND) CO., LTD.**  
133 Moo 5, Bangkadi Industrial  
Park, Thvanon Road, Pathumthani,  
12000, Thailand  
Tel : +66-2-501-1180  
Tel : +66-2-501-1188  
e-mail : satake@asia.com  
URL : http://www.satake@asia.com

**SATAKE INTERNATIONAL BANGKOK CO., LTD.**  
888/84 Mahatun Plaza Bld., 8th  
Floor, Ploenchit Rd., Lumpini,  
Pathumwan, Bangkok, 10330,  
Thailand  
Tel : +66-2-651-5845  
Fax : +66-2-651-5848  
e-mail : satake@asia.com

**SATAKE MANUFACTURING (SUZHOU) CO., LTD.**  
229 Jin Feng Road, Suzhou New  
District, Suzhou, Jiangsu Province,  
215129, China  
Tel : +86-512-6536-8225  
Fax : +86-512-6536-5922  
e-mail : satake@satake.cn

**SATAKE AUSTRALIA PTY. LTD.**  
15 Leland Street, Penrith, N.S.W.,  
2750, Australia  
Tel : +61-2-4725-2600  
Fax : +61-2-4725-2601  
e-mail : info@satake.com.au  
URL : www.satake.com.au

SATAKE CORPORATION has  
obtained ISO 9001 and ISO  
14001 certification.  
These international standards  
for management systems  
ensure Satake will continue to  
provide high quality products  
and services.

ISO 9001 Certification  
(Quality Management Systems)  
ISO 14001 Certification  
(Environmental Management Systems)